



Fire-Lite® Alarms
INCORPORATED

September 25, 1997

C-100

FIRE•COMMAND•25/50 **Voice Evacuation Control Panel**

Section: Emergency Voice Evacuation

GENERAL

The **Fire-Lite FIRE•COMMAND•25/50** is a state-of-the-art, compact, stand-alone or slave Emergency Voice Evacuation Control Panel (VECP). The **FIRE•COMMAND•25/50** is offered in a self-contained, cost-effective design and includes a 25 Watt, 25 V_{RMS} audio amplifier, commercial-grade emergency communications microphone and alert tone generator, standard. Additionally, an integral digital message generator provides a factory prerecorded voice announcement and field record and playback capability.

The **FIRE•COMMAND•25/50** is suitable for use as an adjunct to most UL listed Fire Alarm Control Panels (FACP) in *slave applications* or as a *stand-alone* system with the addition of an optional power supply/battery charger. Other options include a 25 Watt, 25 V_{RMS} audio amplifier for system expansion to 50 Watts (providing dual 25 Watt speaker circuits) or as a secondary, backup amplifier in jurisdictions requiring such. A 70.7 V_{RMS} converter is also available for independently converting amplifiers to meet retrofit needs (*consult factory for availability*).

A host of field-programming options, including dual-message capability (fire, weather, non-fire, multi-language), makes the **FIRE•COMMAND•25/50** the most versatile voice evacuation system available. Suitable applications include, but are not limited to: schools, auditoriums, dormitories, theaters, restaurants, places of worship, motels/hotels, office buildings, factories, etc.

STANDARD FEATURES

- Integral 25 Watt, 25 V_{RMS} audio amplifier with single Class A or Class B speaker circuit.
- Standard, commercial-grade emergency communications microphone.
- Integral Digital Message Generator with standard, factory prerecorded emergency evacuation message.
- Integral message generator includes 60 second capacity, with primary and secondary message capability (30 seconds each).
- Custom messages are field recordable without the addition of costly add-on modules utilizing microphone or audio input jack.
- Digital message may be field-selected for 3, 4, 6, 8 or infinite repeat.
- Built-in alert tone generators with steady, slow whoop, high/low or chime tone capability.
- Field-selectable lead-in/trailing tone selection.
- Alert tone selection may be field-programmed to conform with ANSI S3.41 *Audible Emergency Evacuation Signal* (Temporal Pattern), per NFPA.
- Dual-optically-isolated, trigger input circuits are independently field-programmable for activation by

PATENT PENDING



S2424



California
State Fire
Marshal

6911-0075:181

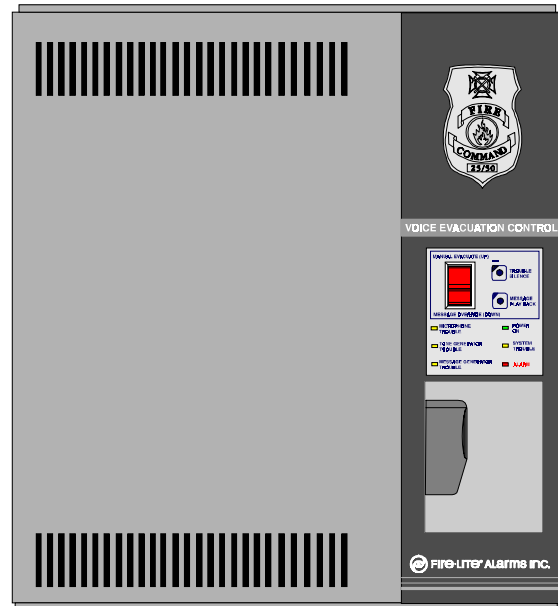

- polarity reversal (host FACP NAC) or dry contact-closure.
- Powered from a host FACP's auxiliary power output or an external UL listed power supply, such as Fire-Lite's FCPS-24F, in *slave applications*.
- Two-position switch provides ALL-CALL or Manual Evacuate functions.
- Integral diagnostic LEDs include: Power, System Trouble, ALARM, Microphone Trouble, Message Generator Trouble, Tone Generator Trouble, Amplifier Fault and others.
- For ease of service and maintenance, plug-in style terminal blocks are utilized for most field-wiring terminations.
- Independent Form-C trouble relay allows FACP to monitor voice system while in active (alarm) state.
- Integral piezo provides local audible indication for troubles.
- Fully supervised, including integral microphone, amplifier output, message generator, speaker wiring and tone generators, in *Standby* and *Active* states.
- **Independent** amplifier supervision: current limit, audio level, short circuit protection.

This document is not intended to be used for installation purposes. We try to keep our product information up-to-date and accurate. We cannot cover all specific applications or anticipate all requirements. All specifications are subject to change without notice. For more information, contact **Fire-Lite**. Phone: (203) 484-7161 FAX: (203) 484-7118



12 Clintonville Road, Northford, Connecticut 06472

ISO-9001
Engineering and Manufacturing
Quality System Certified to
International Standard ISO-9001



Made in the U.S.A.

- All outputs fully power-limited to meet latest UL requirements.
- Current in-rush protection (limits current draw from external power supply during cold start).
- Auxiliary power output provides local power for addressable control modules when used to activate FIRE•COMMAND.
- Unique amplifier design features high signal-to-noise ratio.
- Utilizes Surface Mount Technology.
- Compatible with ALL Fire•Lite Fire Alarm Control Panels, as well as other manufacturers'.
- Aesthetically pleasing design has similar look and feel to Fire•Lite's popular FACPs.
- Background music requires AHJ approval.
- When employing background music option, the FC-PSM power supply module **must** be installed.
- When employing background music option, total output power, per amplifier, is reduced to 20 watts.

OPTIONAL MODULES

FC-AAM25

- 25 Watt, 25 V_{RMS} audio amplifier module.
- Field-programmable for system expansion to 50 Watts (providing dual 25 Watt speaker circuits) or as a backup to the primary 25 Watt amplifier, where required.
- Provides single Class A or Class B speaker circuit.
- Utilizes plug-in style terminal blocks for ease of service and maintenance.
- Fully supervised and power-limited.
- Diagnostic LEDs include: yellow trouble LED (cable fault, 70 V_{RMS} fault, amp fault) and green, amp functional LED.

FC-PSM

- Optional power supply/battery charger module for stand-alone applications.
- Ground fault detection with diagnostic LED (yellow).
- Brownout detection with battery transfer.
- Battery trouble detect with diagnostic LED (yellow).
- Battery saver operation.
- Independent AC loss relay provides AC loss delay per UL, for independent monitoring by DACT (2 Amps at 24 VDC).
- AC power on LED (green).
- 17 AH battery charging capacity — up to 7 AH may be utilized in FIRE•COMMAND enclosure. 12 AH - 17 AH require Fire•Lite BB-17F battery box.
- Large, teeter-plate terminal blocks easily accept up to 12 AWG for power terminations.
- Required when employing background music option.

FC-XRM70 *(consult factory for availability)*

- Converts 25 V_{RMS} audio outputs to 70.7 V_{RMS} for retrofit applications.
- Plugs directly on FC-AAM25 module(s), allowing independent conversion to 70.7 V_{RMS}.

FC-LPS

- Provides local digital message playback for user review of field-recorded custom messages.

STANDARDS AND CODES

The FIRE•COMMAND•25/50 complies with the following standards: **NFPA 72-1993** National Fire Alarm Code; **NFPA**

101-1994 Life Safety Code; **UL 864** Standard for Control Units for Fire Alarm Systems.

SPECIFICATIONS

SLAVE APPLICATIONS

Primary Power:

- 24 VDC (19.1 - 26.4) regulated, filtered, power-limited.

Standby Current:

- 180 mA maximum @ 1 amplifier, 210 mA maximum @ 2 amplifiers.

Alarm Current:

- 2.0 Amps DC maximum @ 1 amplifier, 4.0 Amps DC maximum @ 2 amplifiers.

CAUTION: *Ensure proper available current from host FACP auxiliary power output or power supply UL-listed for Fire Protective Signaling Service to support alarm current drain.*

Dual Command Input Circuits:

- Trigger input Voltage: 10.5 - 29 VDC (UL tested range -15%, +10%).

Note: When programmed for reverse-polarity activation.

Trouble Contact Rating:

- 2.0 Amps at 30 VDC (resistive), 0.6 amps @ 125 VAC (resistive).

Auxiliary Power Output:

- Specific application power - 24 V, 35 mA.

*STAND-ALONE APPLICATIONS

*Primary (AC) Power - Stand-alone applications:

- 1.0 Amp max. @ 120 VAC, 50/60 Hz.

*Secondary Power (Battery) Charging Circuit:

- Supports lead acid batteries only.
- Float charge voltage: 27.6V.
- Maximum charge current: 800 mA.
- Maximum battery charging capacity: 17 AH (batteries greater than 7 AH require BB-17F battery box).

**Note: requires optional FC-PSM Power Supply/Battery Charger Module for stand-alone applications.*

CABINET SPECIFICATIONS

Door: 18.65" (473.71 mm) high x 15.65" (397.51 mm) wide x 1.08" (27.43 mm) deep.

Backbox: 18.50" (469.90 mm) high x 15.50" (393.70 mm) wide x 4.25" (107.95 mm) deep.

Trim ring: *outer measurement* 21.62" (549.15 mm) high x 18.62" (472.95 mm) wide; *inner opening* 18.625" (473.07 mm) high x 15.625" (396.87 mm) wide; with six holes for #8-32 screws and cutouts for hinges.

CONTROLS AND INDICATORS

LED INDICATORS

1. Power On (green).
2. ALARM (red).
3. System Trouble (yellow).
4. Microphone Trouble (yellow).
5. Message Generator Trouble (yellow).
6. Tone Generator Trouble (yellow).
7. Record (green).
8. Playback (green).

SWITCH CONTROLS

1. Record.
2. Silence.
3. Playback.
4. Manual Evacuate.
5. All Call.

ORDERING INFORMATION

FC-25/50 — 25 Watt, 25 VRMS, slave Emergency Voice Evacuation Control Panel (VECP), with integral microphone, digital message generator and single Class A or Class B speaker circuit.

FC-AAM25 — Optional 25 Watt, 25 VRMS Audio Amplifier Module with single Class A or Class B speaker circuit.

FC-PSM — Optional 120 VAC, 60 Hz Power Supply/Battery Charger Module for stand-alone applications.

FC-XRM70 — Optional 70.7 VRMS Converter Module (1 required per amplifier) (*consult factory for availability*).

FC-LPS — Optional Local Playback Speaker.

FC-TR — Trim Ring — semi-flush mounting.

PS-1270 — Battery, 12 volt, 7.0 AH (two required for stand-alone applications).

PS-12120 — Battery, 12 volt, 12.0 AH, (two required for stand-alone applications — requires BB-17F Battery Box.)

PS-12170 — Battery, 12 volt, 17.0 AH, (two required for stand-alone applications — requires BB-17F Battery Box.)

BB-17F — Battery Box, required to mount PS-12120 or PS-12170 batteries.

SYSTEM CONFIGURATION

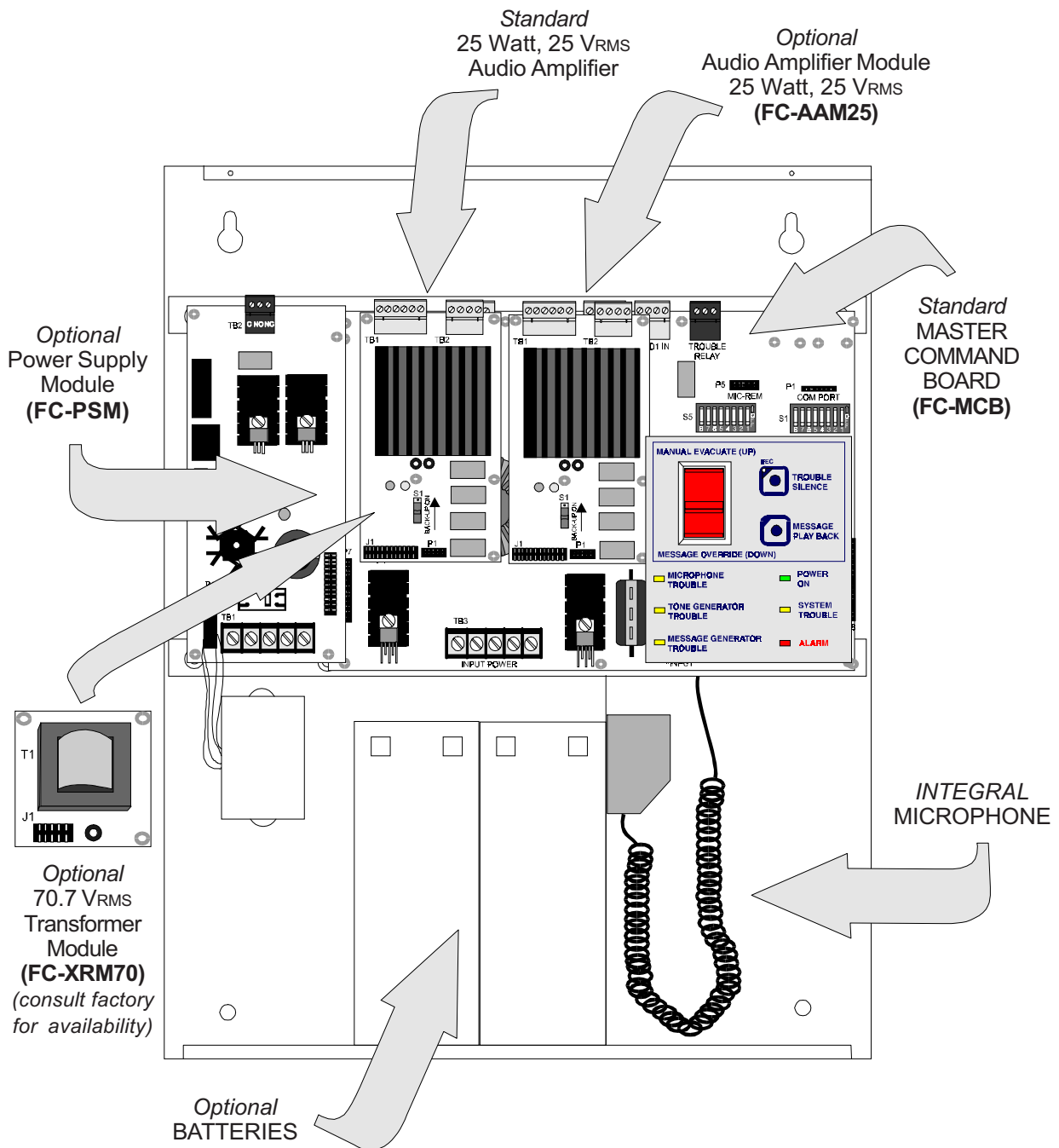

APPLICATIONS EXAMPLES

One Speaker Circuit — One 60s Message — 25 Watts

A very basic application consists of one FIRE•COMMAND•25/50 Master and one amplifier with a single speaker circuit. A second amplifier can be installed as a backup if desired. This configuration is suitable for small facilities requiring no more than 25 watts of output power. A single fire evacuation message will be generated during an alarm condition from the host FACP.

In this application, the NAC from the host FACP is connected to CMD1. The CMD1 out terminals are then terminated with an EOL for a Style Y Notification Appliance Circuit (NAC) or the terminals are wired back to the host FACP for a Style Z NAC. S5 DIP switch 2 is set to OFF which causes the speaker circuit to be activated by the CMD1 input. S5 DIP switch 5 is set to OFF which causes CMD1 input to be activated by a reverse polarity condition.

NOTE: FIRE•COMMAND•25/50 may be configured for use as a manual evacuate system only, without need for FACP NAC or contact closure for activation (trigger).

One Speaker Circuit One 60s Message 25 Watts

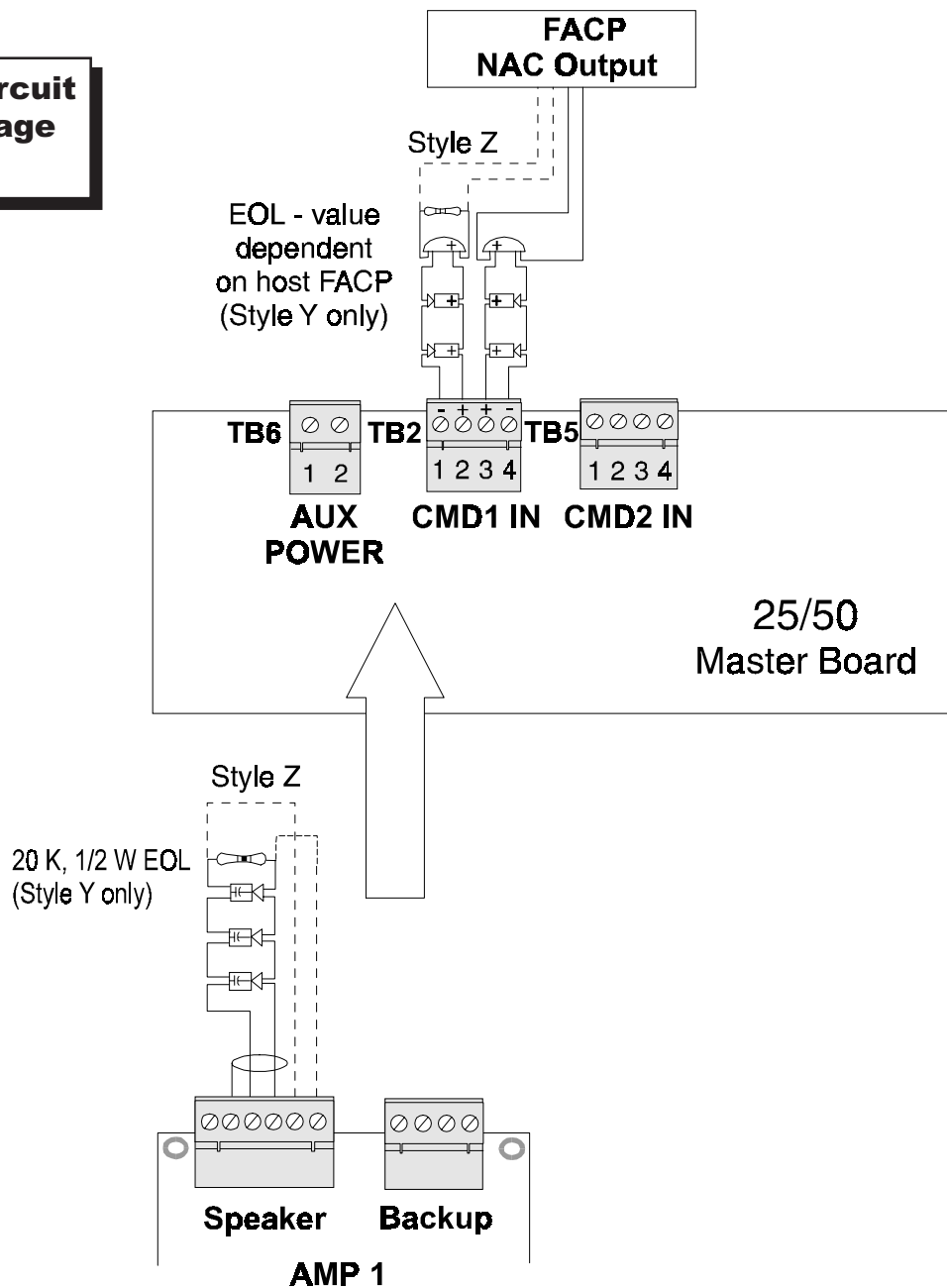

Two Speaker Circuits — Two 30s Messages (Fire and Non-Fire) — 50 Watts

This application consists of one FIRE•COMMAND•25/50 Master and two speaker circuits which requires installation of the optional second amplifier (FC-AAM25). This configuration is suitable for small facilities requiring no more than 50 watts of output power (providing dual 25-watt speaker circuits). A fire evacuation message (primary) will be generated over both speaker circuits during an alarm condition from the host FACP and an emergency (secondary) 'non-fire' message (e.g., weather alert) can be manually generated over both circuits.

In this application, the NAC from the host FACP is connected to CMD1. The CMD1 out terminals are then terminated with an EOL for a Style Y NAC or the terminals are wired back to the host FACP for a Style Z NAC. CMD2 is connected to a normally open contact which can be used to manually generate an emergency 'non-fire' message (e.g., Tornado MFA).

S5 DIP switch 2 is set to ON which causes transmission of the primary 'fire' message over speaker circuits 1 and 2 upon activation of CMD1 and transmission of the secondary 'non-fire' message over speaker circuits 1 and 2 upon activation of CMD2. S5 DIP switch 5 is set to OFF which causes CMD1 input to be activated by a reverse polarity condition and S5 DIP switch 6 is set to ON which causes CMD2 input to be activated by a contact closure.

NOTES: 1) FIRE•COMMAND•25/50 may be configured for use as a manual evacuate system only, without need for FACP NAC or contact closure for activation (trigger). 2) Command input one (CMD1 - primary message) activation overrides command input two (CMD2 - secondary message) activation.

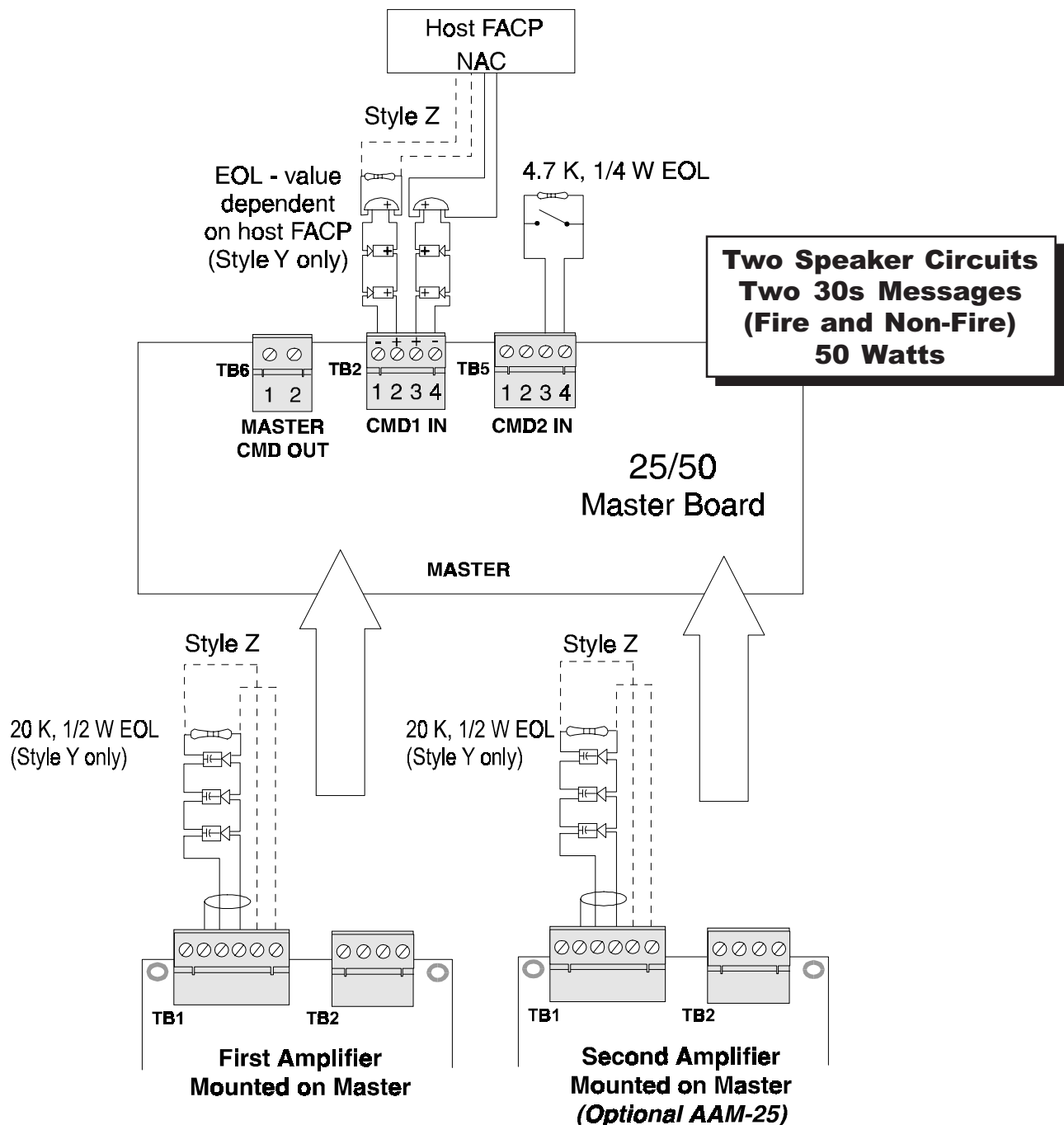

One Speaker Circuit — One 60s Message — 25 Watts Backed-Up

This application consists of one FIRE•COMMAND•25/50 with one amplifier and a single speaker circuit. A second amplifier can be installed as a backup if desired. This configuration is suitable for small facilities requiring no more than 25 watts of output power. A single 60 second fire evacuation message will be generated during an alarm condition from the host FACP or activation of the Manual Evacuate switch.

In this application, the NAC from the host FACP is connected to CMD1. The CMD1 out terminals are then terminated with an EOL resistor for the FACP's Style Y NAC or the terminals are wired back to the host FACP for a Style Z NAC. S5 DIP switch 2 is set to OFF which causes the speaker circuit to be activated by the CMD1 input. S5 DIP switch 5 is set to OFF which causes CMD1 input to be activated by a reverse polarity condition.

Backup Amplifier switch S1 is set to the 'Backup ON' position. 18 AWG or larger jumpers connect the Backup Amplifier TB2 Terminal 3 and Main Amplifier TB2 Terminal 2, as well as Backup Amplifier TB2 Terminal 4 and Main Amplifier TB2 Terminal 1. Upon failure of the first or main amplifier, the audio from the backup amplifier will be switched out to the speakers.

NOTE: In the optional 70 VRMS configuration, only the amplifier is backed up; the FC-XRM70 coupling transformer is not. For this reason, it is not necessary to install an FC-XRM70 transformer module on the backup amplifier.

